

OptoLed

Saving Energy





AFC LIGHTING / OPTOLED, Lighting with expert staff, the manufacture of interior and exterior lighting fixtures, lighting desing, engineering services, installation and commissioning during the consultation, after-sales service issues serve. We contounie produce in two different facilities in a closed 6500 m2 within 10.000 m2 total plant area, to produce standard and decorative lighting poles.

Aluminum Die-Cast Plant

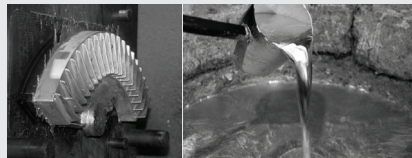

Surface Mounting Technology

Our Engineers design the electronic cards and components for our fixtures.



The machine, is the most important factor for mass production of , has 40,000 pieces per hour electronic component placement capacity



Powder Coating Plant

We can paint up to h:14mt. Products in our two different powder coating plant.



Mold Production Area

We can make die-cast aluminum mold, plastic injection mold and cast aluminum mold in our factory.

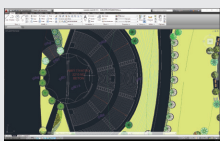

Project Department

Your project is prepared by AutoCAD then define solutions details in infrastructure. Our Lighting Simulation Team includes professional engineers who are experts in performing lighting simulations software such as Dialux.

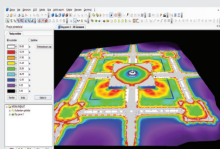

Our designers, in line with the work of project engineers, as your project is Created by realistic presentations by 3D Max, V-Ray , After Effect and high-level video editing software such as Visualization and Effect.



OptoLed
Saving Energy

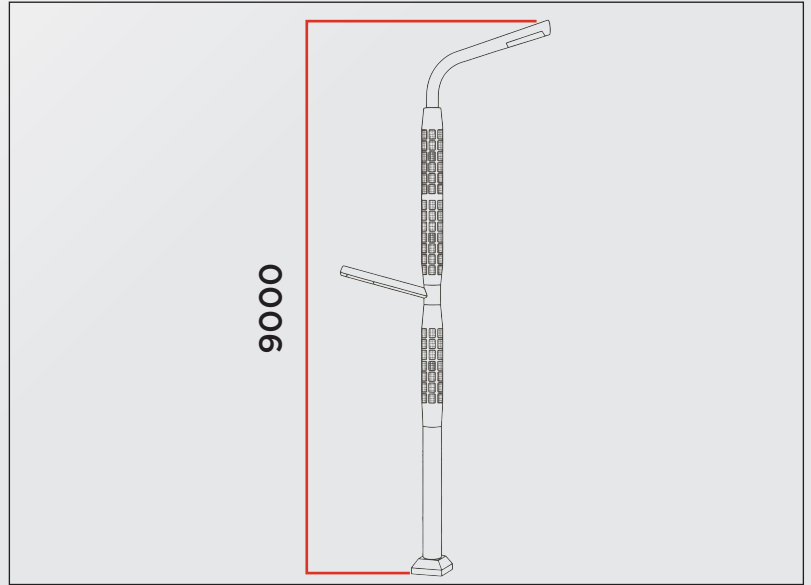
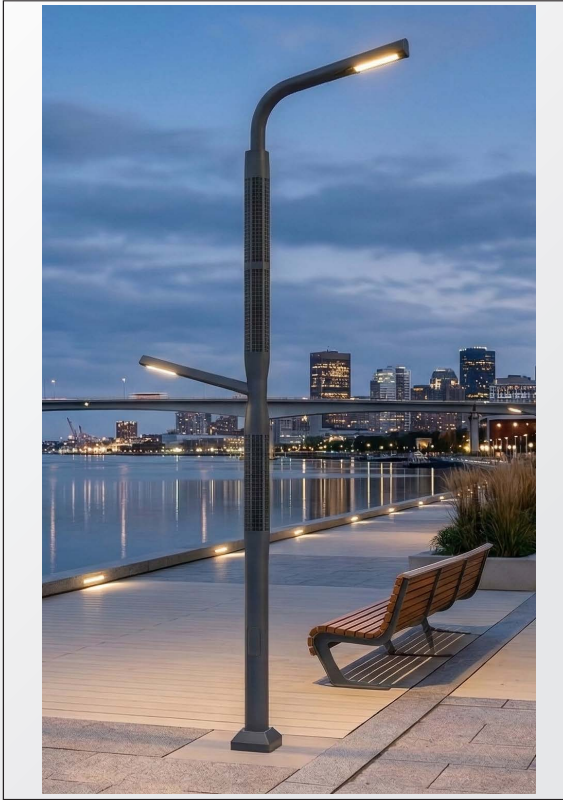

120 Watts	3000K - 6500K	IP65	IK08
-----------	---------------	------	------

Electrical Details

Input Voltage (V)	220 - 240 VAC
Frequency (Hz)	50/60 Hz
Power Consumption (W)	120W
Power Factor	>0.9
Current (mA)	400mA - 1500mA
Surge Protection	4kV, Internal
Electrical Installation Grade	Class I

Electric and Electronic Components

Printed Circuit Board(s) (PCBs)	FR4, 1,60mm Aluminum Board
LED Chip(s)	Cree, LUMILEDS
LED Chip Type	Power LED/Mid Power LED
LED Driver(s)	Meanwell, OSRAM
Optics	LEDIL
Anti-glare	Diffuser
Cable(s)	2x0,75mm TTR(H05VV-F) 3x1,50mm TTR(H07RN-F)
Connector(s)	3 Pin Solder I Type Female-Male Waterproof

Pole Body Specs

Dimensions	Ø219mm-114mmX3mm
Body Type	Conical Pole
Material	Galvanized Steel

Solar Details

Solar Panel Dimensions	1240mm
Solar Panel	3x120Wp Solar Panel
Battery	1638 Whr LiFePO4
Charger	MPPT

Product Datasheet

Product Description

Product Type	Lighting Pole
Product Name	Larus
Installation Environment	Outdoor
Application Areas	City, Highway, Promenades
Applicable Mounting Settings	On Ground
Light Distribution	Asymmetrical

Mechanical Details

Luminaire Housing	Aluminum Body
Base Body	Aluminum Body
Heatsink	Aluminum Injection
Anchor Plate	Yes
Diffuser Options	Optic Lens
Fasteners	A4 Stainless Steel (EN ISO 3506-1)
Pre-coating
Final Coating	Electrostatic Powder Coating
Coating Color Options	Customized (RAL Catalogue)
Ingress Protection (IP Rating)	IP65
Impact Resistance (IK Rating)	IK08

Optical Details

Beam Angle	Asymmetrical
Color Rendering Index (CRI)	>80
Luminous Efficiency	130 - 150 lm/W
Luminaire Luminous Flux	2x7800 lm - 2x9000 lm

Product Configurations

Height	Power (W)	Luminous Flux (Lm)	Color Temperature (K)	CRI
9mt.	2x60W	2x9000lm.	4000	>80



